

Data sheet and installation information

1. Machine configuration and overall dimensions



e'6 / e'6m

e'6	e'6	e'6m
w/h/d mm w/h/d (inch)	840/713/600 (33 / 27.9 / 23.6)	840/713/600 (33 / 27.9 / 23.6)
weight kg weight (lb)	142 313	150 330

Capacity

Coffee	525 Espresso / hour at 23s extraction time 6 Espresso at the same time
Steam	Autosteam, temperature controlled Everfoam, fully automatic frothing (option) Second steam wand (option)
Hot Water	150 hot water units / hour / 200ml (6.8 oz US)
Milk system	350 Cappuccino / hour

Technical data

Brew chamber	3 x up to 24g
Grinding	4 x drive ceramic grinder disk
User Interface	3 x 8" colour touch screen
Bean hoppers	4 x 1.5kg (3.3 lb)
Coffee spout hgt	65mm to 165mm (2.55 to 6.49 inch)
Interface	USB, SD-Card, Ethernet, Serial, RS-232, CCI
Standby mode	less than 2W
Steam boiler size	e'6: 8 litre (2.11 gal US) e'6m: 5.6 litre (1 x 1.48 gal US)
Coffee boiler size	3 x 1.5 litres (3 x 0.39 gal US)
Lighting concept	Front panel full colour LED

2 Power cords

Power requirement A

Single-phase	1/N/PE, 220-240V~, 50/60Hz, 25A, 5.8kW
Two-phases	2/PE, 200-210V~, 50/60Hz, 30A, 4.9kW
Three-phases	3/N/PE, 380-420V~, 50/60Hz, 15A, 9.6kW
Three-phases (Triangle)	3/PE, Δ 220-230V~, 50/60Hz, 20A, 5.8kW

Power requirement B

Single-phase	1/N/PE, 220-240V~, 50/60Hz, 15A, 3.0kW
Two-phases	2/PE, 200-210V~, 50/60Hz, 15A, 2.5kW

Water Connection

Water	G3/8" female, 2.5 - 4 bar,
Water hose	2 m length (78.7 inch)
Drain	Self priming (see drawing rear side)

Water quality	Total hardness: 5 - 8°dGH (89-142 ppm) Carbonate hardness: max. 6°dKH (107 ppm) pH value: ideal 7.0 - 7.2
---------------	---

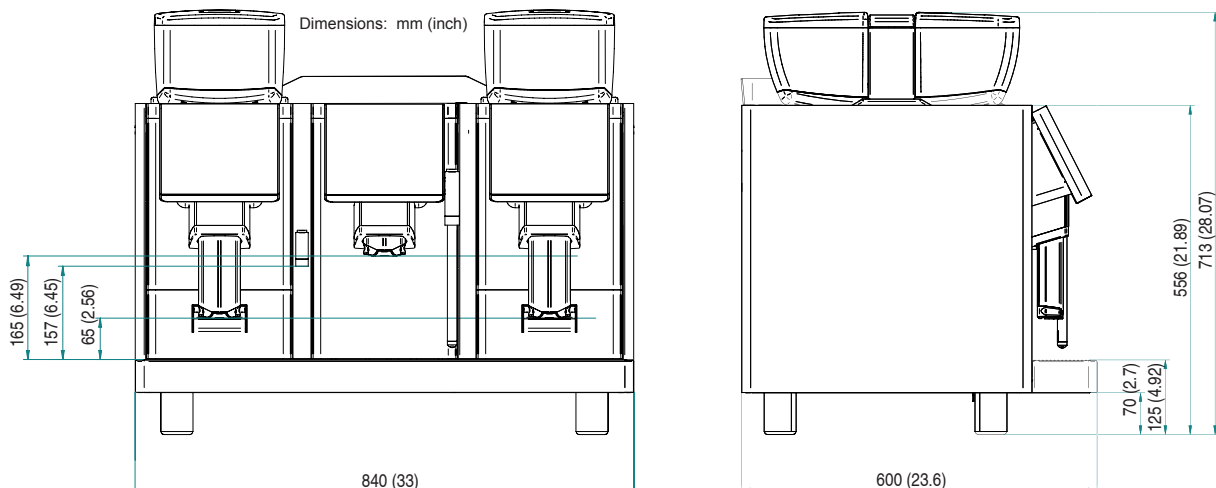

2. Prior to the installation, READ SAFETY INSTRUCTIONS

- Check water quality
- Define filter type and size and check space inside counter
- If no descaling cartridge is used, install carbon filter as minimum
- Check required desk for machine
- Check counter cut out
- Check water supply installation
- Check power supply installation
- Check all with customer on site
- Make sure original coffee is available
- Make sure cold milk is available
- Check drinks recipes and cup sizes
- Organize milk pitcher

3. After installation

- Instruct staff using Quick reference card
- Fill in installation warranty sheet and send it back to Eversys

4. Desk preparation

mm (inch)

