



MAGIC

Installation Site Preparation Checklist

GENERAL MACHINE ENVIRONMENT

- The installation area is clean and clear of dust and tools. It is not located in an active construction zone.
- The counter accommodates the machine size and weight:
 - Dimensions: 11.0" (W) x 18.5" (H) x 18.9" (D)
 - Weight: 33.0 lb
- Machine can safely be installed with minimum clearance:
 - Top: 16" – Filling the machine from the top and access the tanks.
 - Sides: 8" – Opening the service compartment doors.
 - Back: 4" – Electrical and water connections space.

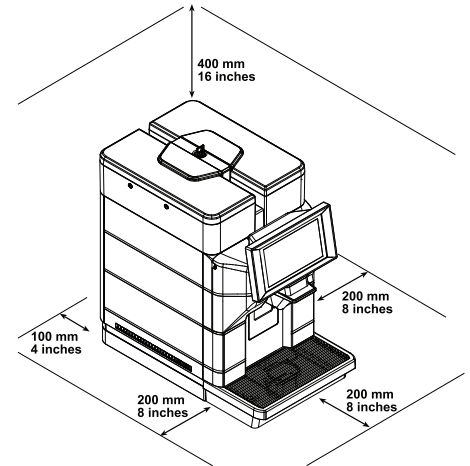

ELECTRICAL REQUIREMENTS

HIGHLY RECOMMENDED: Work with a qualified professional electrician to ensure everyone safety and avoid costly machine damages due to improper electrical set-up.

Magic Specifications	120 V, 60 Hz, 1300 W NEMA 5-15 Plug
-----------------------------	----------------------------------------

- Power outlet receptacle is NEMA 5-15R.
- Dedicated breaker.
- No extension cord or power strip on the circuit.

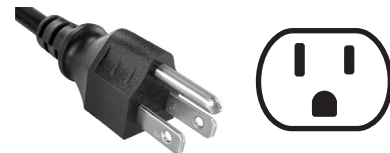

WATER SPECIFICATIONS

HIGHLY RECOMMENDED: Consult a water treatment specialist to analyze the onsite water and make sure it meets the machine requirements, which may require a water treatment system (not provided).

- pH range is between 6.5 & 7.5.
- Hardness (TDS) is between 89 PPM & 142 PPM.

Water Network Option

- Pressure is between 1.5 bar & 8 bar.
- The water network provides cold, drinkable tap water.
- Dedicated 3/8" diameter water line.
- Shutoff valve with a 3/8" G male pipe fitting on machine's end.
- Machine water line is equipped with softness/filtration system and descaling device.